

STOP VALVE zGLO



Body material	Nominal pressure	Nominal diameter	Max. temperature
A Grey cast iron	A 6 bar C 16 bar	DN 15-300	300°C
C Nodular cast iron	C 16 bar D 25 bar	DN 15-200	350°C
E Bronze	C 16 bar B 10 bar A 6 bar	DN 15-125 DN 150-200 DN 250-300	225°C
F Cast steel	E 40 bar	DN 15-150*	400°C
I Cast stainless steel	E 40 bar	DN 15-200	400°C



correspond to the pressure equipment directive 2014/68/UE marking CE for DN≥32

FEATURES

- high tightness (leakproofness class - A acc. to EN - 12266 - 1
- compact settlement
- environment friendly
- tests acc. to EN - 12266 - 1
- face-to-face dimension according to EN 558 series 1
- flanges drilled according to EN 1092-2 for body material A, C, E
- flanges drilled according to EN 1092-1 for body material F

APPLICATION *

*not all of the applications are suitable for all of the executions

industries						
	INDUSTRY	SHIPBUILDING INDUSTRY	HEATING	REFRIGERATION AND AIR CONDITIONING		
media						
	GLYCOL	INDUSTRIAL WATER	DIATHERMIC OIL	STEAM	COMPRESSED AIR	NEUTRAL FLUIDS

Data given can be changed without notice.

Edition 01/2018

FIG.215

MATERIALS, DIMENSIONS

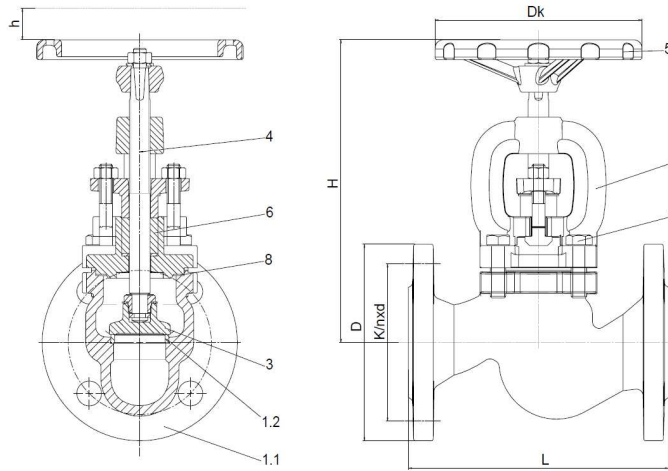

	Body material	A				C			E	
		00	01 04 71 91	02 05 72 92	03 13	01 04 71 91	02 05 72 92	03 13	03 23 73 93	
1.1	Body	EN – GJL-250 5.1301 (ex. JI1040)				EN – GJS-400 – 18-LT 5.3103 (ex. JS1025)			CuSn5Zn5Pb5-C CC491K	
1.2	Seat ring	X12Cr13 1.4006		CuSn10 – C CC480K		X12Cr13 1.4006		CuSn10 – C CC480K	CuSn5Zn5Pb5-C CC491K	
2	Bonnet	EN-GJL-250 5.1301 (ex. JI1040)				EN – GJS-400 – 18-LT 5.3103 (ex. JS1025)			CuSn5Zn5Pb5-C CC491K	
3	Disc	X20Cr13 1.4021		CuSn10 – C CC480K		X20Cr13 1.4021		CuSn10 – C CC480K	CuSn5Zn5Pb5-C CC491K	
4	Stem	X20Cr13 1.4021		CuZn40Mn1,5	CuSn10 – C CC480K	X20Cr13 1.4021		CuZn40Mn1,5	CuSn10 – C CC480K	CuZn35Ni
5	Hand-wheel	EN-GJS500-7 5.3200 (ex. JS1050)								
6	Gland packing	Graphite								
7	Hexagon bolt	5.6				A2-70		5.6		A2-70
8	Gasket	Graphite + NiCr								
Max. temperature		300°C	300°C	225°C		350°C		225°C	225°C	

DN	15	20	25	32	40	50	65	80	100	125	150	200	250	300	
L (mm)	130	150	160	180	200	230	290	310	350	400	480	600	730	850	
Dk (mm)	100		120		160		180	200	250		320	360		500	
H		167		175	186	235	248	260	291	338	373	429	529	638	710
	215-91	189	189	205	221	249	262	298	335	377	427	476	695	826	888
h (mm)		5	5,5	7	14	20	25	35	41	31	48	54	77	120	120
	215-71 91	14	14	25	30	24	32	42	48	50	50	60	80	100	100
Kvs (m³/h)	5,9	7,4	13,0	18,0	30,0	41,0	79,0	115	181	225	364	690	1010	1460	
Weight (kg)															
215		3,3	3,9	5,0	6,6	9,4	12,0	17,3	22,7	35,8	52,8	74,2	126	200	315
	215-31	3,3	3,9	5,0	6,6	9,4	12,0	17,3	22,7	35,8	52,8	74,2	126	200	315
	215-71	3,3	3,9	5,0	6,6	9,4	12,5	17,6	24,0	36,8	52,6	76,5	126	200	315
	215-91	3,3	3,9	5,0	6,6	9,4	12,5	17,6	24,0	36,8	52,6	76,5	126	200	315

Data given can be changed without notice.

Edition 01/2018

KV [m³/h] FIG. 215-71, 91

Turn	DN 15	DN 20	DN 25	DN 32	DN 40	DN 50	DN 65	DN 80	DN 100	DN 125	DN 150	DN 200	DN 250	DN 300
0,5	1,49	1,56	1,08	2,14			7,7		9,5	17	29			
1	1,78	1,94	1,96	3,05	6,9	9,6	9,8	11,5	18	31	49	70	95	160
1,5	2,14	2,35												
2	2,45	2,78	3,57	5,09	12,1	16,4	18,2	21,5	37,5	58	88	130	175	280
2,5	2,78	3,18												
3	3,03	3,58	5,17	7,06	16,3	22,4	26,5	32	56	84	127	190	272	386
3,5	3,30	3,99												
4	3,64	4,54	6,44	8,89	20,2	27,6	34,1	41,5	71	108	165	250	355	489
4,5	4,15	5,35												
4,7	4,50	5,67												
5			7,4	10,4	25,0	33	41,3	50	85	132	199	303	421	585
6			8,3	11,8	28,3	39	47,9	59	103	160	232	350	487	675
7			9,2	13,1		43,5	54,8	69	121	191	263	407	551	767
8			10,6	14,1		45,1	61,6	79	139	220	294	436	611	862
8,33			10,9											
9				15,4			67,2	88	149	236	314	460	670	958
10				17,3			71	96	157	248	325	483	727	1050
10,5							75,5							
11								100			335	499	783	1140
12								104			342	514	841	1229
13												524	882	1294
13,33												528		
14													921	1354
15													955	1398
16													982	1434
16,66													1001	1453

Data given can be changed without notice.

Edition 01/2018

MATERIALS, DIMENSIONS

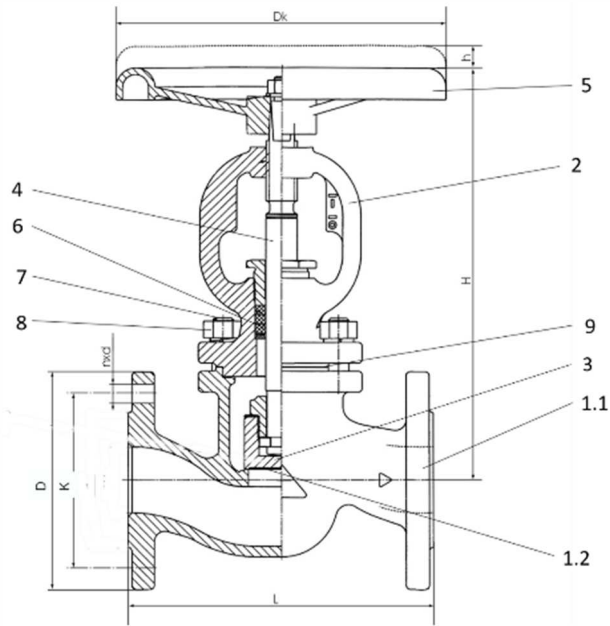

Body material	F	
Type	01 11 71	
1.1 Body	GP240GH+N 1.0619	
1.2 Seat ring	G18 8Mn 1.4370 for type 11-Stellite6	
2 Bonnet	GP240GH+N 1.0619	
3 Disc	X20Cr13 1.4021 for type 11- Stellite6	
4 Stem	X14CrMoS17 1.4104	
5 Hand-wheel	EN-GJS-400-18-LT JS1025	
6 Gland packing	Graphite	
7 Stud bolt	42CrMo5 1.7233	
8 Nut	C35E 1.1181	
9 Gasket	Graphite + NiCr	
Max. temperature	400°C	

DN	15	20	25	32	40	50	65	80	100	125	150	200
L (mm)	130	150	160	180	200	230	290	310	350	400	480	600
Dk (mm)	120	120	120	180	180	250	250	250	250	320	320	400
H (mm)	208	208	208	248	248	332	332	407	407	571	571	571
h (mm)	6	6	6	10	10	16,5	16,5	25	25	40	40	92
Kvs (m ³ /h)	4,3	7,0	11,0	17,5	27,0	47,0	68,0	116,0	162,0	250,0	364,0	550,0
Weight (kg)	4,3	5,1	5,8	9,5	9,8	17,5	20,5	34	44	77	113	180

Data given can be changed without notice.

Edition 01/2018

ZETKAMA Sp. z o.o.
Ul. 3 Maja 12
PL 57-410 Ścinawka Średnia

Tel. +48 74 8652 193
Tel. +48 74 8652 111
Fax +48 74 8652 199

E-mail export@zetskama.com.pl
www.zetskama.com

FIG.215

MATERIALS, DIMENSIONS

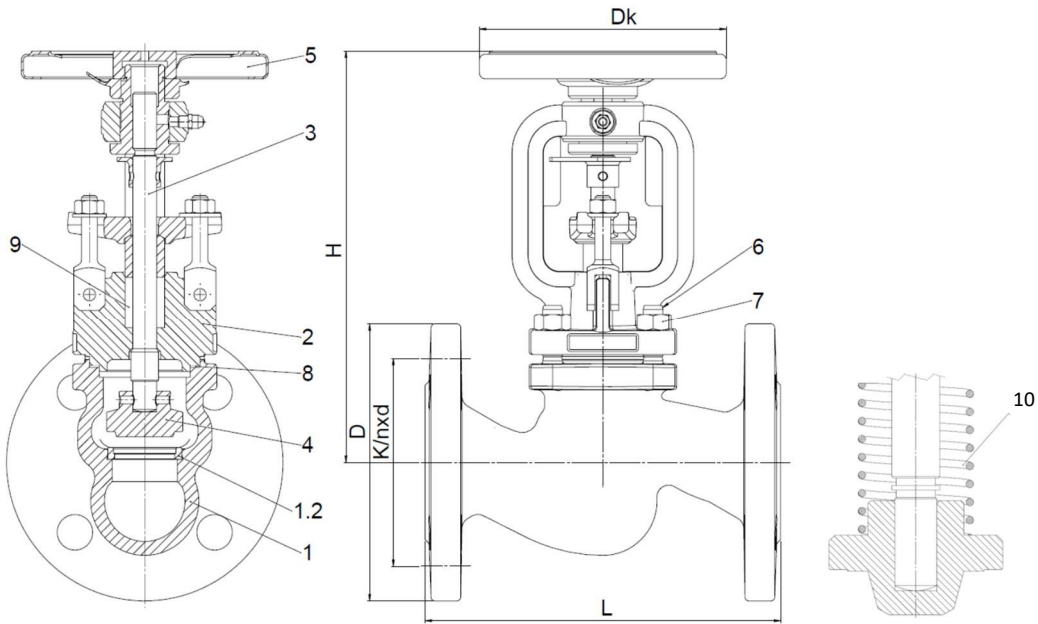

	Body material	I	
		09 10 12	39 40
1	Body	G-X5CrNiMo19-11-2 1.4408	
1.2	Seat	X5CrNiMo17-12-2 1.4401/ stellite	
2	Bonnet	G-X5CrNiMo19-11-2 1.4408	
3	Stem	X6CrNiMoTi17-12-2 1.4571	
4	Disc	X6CrNiMoTi17-12-2 1.4571	
5	Hand-wheel	Steel	
6	Stud bolt	A4-70	
7	Nut	A4	
8	Bonnet gasket	Graphite + NiCr	
9	Gland packing	Graphite	
10	Spring	----	X17CrNi16-2
Max. temperature		400°C	

DN	15	20	25	32	40	50	65	80	100	125	150	200
L (mm)	130	150	160	180	200	230	290	310	350	400	480	600
Dk (mm)	125	125	125	125	200	200	250	250	300	300	400	500
H	205	205	205	210	250	250	280	320	425	470	495	613
Kvs (m³/h)	5,3	8,4	12,3	22	29	44	74,8	111,5	182	232,5	337,5	1078
Weight (kg)	4,3	5,0	5,8	7,5	11,7	14,2	20,4	26,9	44,5	65,2	93	157

Data given can be changed without notice.

Edition 01/2018

ZETKAMA Sp. z o.o.
Ul. 3 Maja 12
PL 57-410 Ścinawka Średnia

Tel. +48 74 8652 193
Tel. +48 74 8652 111
Fax +48 74 8652 199

E-mail export@zetskama.com.pl
www.zetskama.com

PRESSURE-TEMPERATURE RATINGS

Acc. EN 1092-2	PN		-60°C ÷ <-10°C	10°C ÷ 120°C	150°C	200°C	250°C	300°C	350°C	400°C	450°C	
EN-GJL250	6	bar	-----	6	5,4	4,8	4,2	3,6	---	---	---	
	16		-----	16	14,4	12,8	11,2	9,6	---	---	---	
EN-GJS400-18 LT	16		-----	16	15,5	14,7	13,9	12,8	11,2	---	---	
	25		-----	25	24,3	23	21,8	20	17,5	---	---	
Acc. EN 1092-1			-20° ÷ <-10°C	10°C ÷ 100°C	150°C	200°C	250°C	300°C	350°C	400°C	450°C	
GP240GH +N	40	bar	30	37,1	35,2	33,3	30,4	27,6	25,7	23,8	13,1	
Acc. EN 1092-1			-60° ÷ <-10°C	10°C ÷ 100°C	150°C	200°C	250°C	300°C	350°C	400°C	450°C	
G-X5CrNiMo19-11-2	40		40	40	36,3	33,7	31,8	29,7	28,5	27,4	---	

FLANGE DIMENSIONS ACC. PN-EN 1092-1/-2

DN		15	20	25	32	40	50	65	80	100	125	150	200	250	300
PN6	D (mm)	80	90	100	120	130	140	160	190	210	240	265	320	-----	-----
	K (mm)	55	65	75	90	100	110	130	150	170	200	225	280	-----	-----
	nxd (mm)	4x11	4x11	4x11	4x14	4x14	4x14	4x14	4x14	4x18	4x18	8x18	8x18	8x18	-----
PN16	D (mm)	95	105	115	140	150	165	185	200	220	250	285	340	405	460
	K (mm)	65	75	85	100	110	125	145	160	180	210	240	295	355	410
	nxd (mm)	4x14	4x14	4x14	4x19	4x19	4x19	4x19	8x19	8x19	8x19	8x23	12x23	12x28	12x28
PN25	D (mm)	95	105	115	140	150	165	185	200	235	270	300	360	-----	-----
	K (mm)	65	75	85	100	110	125	145	160	190	220	250	310	-----	-----
	nxd (mm)	4x14	4x14	4x14	4x19	4x19	4x19	8x19	8x19	8x23	8x28	8x28	12x28	-----	-----
PN40	D (mm)	95	105	115	140	150	165	185	200	235	270	300	375	-----	-----
	K (mm)	65	75	85	100	110	125	145	160	190	220	250	320	-----	-----
	nxd (mm)	4x14	4x14	4x14	4x18	4x18	4x18	8x18	8x18	8x22	8x26	8x26	12x30	-----	-----

DISC

Type 04; 05; 13; 14

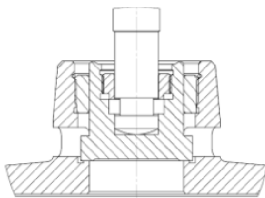

Type 00

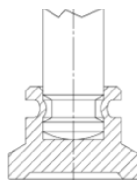

Type 41; 42; 43

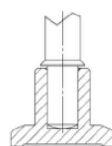

Type 31; 32; 33; 40; 39

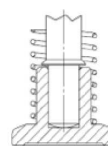

Type 71 91



Data given can be changed without notice.

Edition 01/2018

ZETKAMA Sp. z o.o.
 Ul. 3 Maja 12
 PL 57-410 Ścinawka Średnia

Tel. +48 74 8652 193
 Tel. +48 74 8652 111
 Fax +48 74 8652 199

E-mail export@zetkama.com.pl
www.zetkama.com

TYPE

Figure	Body material	Nominal diameter	Nominal pressure	Type
215	A Grey cast iron EN-GJL-250	15-50 mm	A 6 bar	00 stem and disc connection - fixed – rolled; stem, disc and seat ring - stainless steel
		15-150 mm	A 6 bar	01 stem and disc connection – nut; stem, disc and seat ring - stainless steel
		200-300 mm	A 6 bar	04 stem and disc connection – nut; stem, disc and seat ring - stainless steel; balancing disc
		15-150 mm	A 6 bar	02 stem and disc connection nut; stem - brass, disc and seat ring - bronze
		200-300 mm	A 6 bar	05 stem and disc connection – nut; stem- brass, disc and seat ring – bronze; balancing disc
		15-150 mm	A 6 bar	03 stem and disc connection nut; stem, disc and seat ring - bronze
		200-300 mm	A 6 bar	13 stem and disc connection – nut; stem, disc and seat ring – bronze; balancing disc
		15-300 mm	A 6 bar	31 loose disc with spring; stem, disc and seat ring - stainless steel
		15-300 mm	A 6 bar	41 loose disc without spring; stem, disc and seat ring - stainless steel
		15-300 mm	A 6 bar	32 loose disc with spring; stem - brass, disc and seat ring - bronze
		15-300 mm	A 6 bar	42 loose disc without spring; stem - brass, disc and seat ring - bronze
		15-300 mm	A 6 bar	33 loose disc with spring; stem, disc and seat ring - bronze
		15-300 mm	A 6 bar	43 loose disc without spring; stem, disc and seat ring - bronze
		15-300 mm	A 6 bar	71 stem and disc connection – nut; stem, throttling disc and seat ring - stainless steel; throttling disc; without position indicator
		15-300 mm	A 6 bar	91 stem and disc connection – nut; stem, throttling disc and seat ring - stainless steel; throttling disc; with position indicator
		15-300 mm	A 6 bar	72 stem and disc connection – nut; stem- brass, throttling disc and seat ring – bronze; throttling disc; without position indicator
		15-300 mm	A 6 bar	92 stem and disc connection – nut; stem - brass, throttling disc and seat ring – bronze; throttling disc; with position indicator
		15-50 mm	C 16 bar	00 stem and disc connection - fixed – rolled; stem, disc and seat ring - stainless steel
		15-150 mm	C 16 bar	01 stem and disc connection – nut; stem, disc and seat ring - stainless steel
		200-300 mm	C 16 bar	04 stem and disc connection – nut; stem, disc and seat ring - stainless steel; balancing disc
		15-150 mm	C 16 bar	02 stem and disc connection nut; stem - brass, disc and seat ring - bronze
		200-300 mm	C 16 bar	05 stem and disc connection – nut; stem- brass, disc and seat ring – bronze; balancing disc
		15-150 mm	C 16 bar	03 stem and disc connection nut; stem, disc and seat ring - bronze

Data given can be changed without notice.

Edition 01/2018

FIG.215

		200-300 mm	C 16 bar	13 stem and disc connection – nut; stem, disc and seat ring – bronze; balancing disc
		15-300 mm	C 16 bar	31 loose disc with spring; stem, disc and seat ring - stainless steel
		15-300 mm	C 16 bar	41 loose disc without spring; stem, disc and seat ring - stainless steel
		15-300 mm	C 16 bar	32 loose disc with spring; stem - brass, disc and seat ring - bronze
		15-300 mm	C 16 bar	42 loose disc without spring; stem - brass, disc and seat ring - bronze
		15-300 mm	C 16 bar	33 loose disc with spring; stem, disc and seat ring - bronze
		15-300 mm	C 16 bar	43 loose disc without spring; stem, disc and seat ring - bronze
		15-300 mm	C 16 bar	71 stem and disc connection – nut; stem, throttling disc and seat ring - stainless steel; throttling disc; without position indicator
		15-300 mm	C 16 bar	91 stem and disc connection – nut; stem, throttling disc and seat ring - stainless steel; throttling disc; with position indicator
		15-300 mm	C 16 bar	72 stem and disc connection – nut; stem-brass, throttling disc and seat ring – bronze; throttling disc; without position indicator
		15-300 mm	C 16 bar	92 stem and disc connection – nut; stem - brass, throttling disc and seat ring – bronze; throttling disc; with position indicator
		15-50 mm	C 16 bar	00-D stem and disc connection - fixed – rolled; stem, disc and seat ring - stainless steel epoxy paint
		15-150 mm	C 16 bar	01-D stem and disc connection – nut; stem, disc and seat ring - stainless steel epoxy paint
		200-300 mm	C 16 bar	04-D stem and disc connection – nut; stem, disc and seat ring - stainless steel; balancing disc epoxy paint
215	C Nodular cast iron EN-GJS-400-18-LT	15-150 mm	C 16 bar	01 stem and disc connection – nut; stem, disc and seat ring - stainless steel
		200 mm	C 16 bar	04 stem and disc connection – nut; stem, disc and seat ring - stainless steel; balancing disc
		15-150 mm	C 16 bar	02 stem and disc connection nut; stem - brass, disc and seat ring - bronze
		200 mm	C 16 bar	05 stem and disc connection – nut; stem-brass, disc and seat ring – bronze; balancing disc
		15-150 mm	C 16 bar	03 stem and disc connection nut; stem, disc and seat ring - bronze
		200 mm	C 16 bar	13 stem and disc connection – nut; stem, disc and seat ring – bronze; balancing disc
		15-200 mm	C 16 bar	31 loose disc with spring; stem, disc and seat ring - stainless steel
		15-200 mm	C 16 bar	41 loose disc without spring; stem, disc and seat ring - stainless steel
		15-200 mm	C 16 bar	32 loose disc with spring; stem - brass, disc and seat ring - bronze
		15-200 mm	C 16 bar	42 loose disc without spring; stem - brass, disc and seat ring - bronze
		15-200 mm	C 16 bar	33 loose disc with spring; stem, disc and seat ring - bronze
		15-200 mm	C 16 bar	43 loose disc without spring; stem, disc and seat ring - bronze

Data given can be changed without notice.

Edition 01/2018

FIG.215

	15-200 mm		C 16 bar		71 stem and disc connection – nut; stem, throttling disc and seat ring - stainless steel; throttling disc; without position indicator
	15-200 mm		C 16 bar		91 stem and disc connection – nut; stem, throttling disc and seat ring - stainless steel; throttling disc; with position indicator
	15-200 mm		C 16 bar		72 stem and disc connection – nut; stem- brass, throttling disc and seat ring – bronze; throttling disc; without position indicator
	15-200 mm		C 16 bar		92 stem and disc connection – nut; stem - brass, throttling disc and seat ring – bronze; throttling disc; with position indicator
	15-150 mm		D 25 bar		01 stem and disc connection – nut; stem, disc and seat ring - stainless steel
	200 mm		D 25 bar		04 stem and disc connection – nut; stem, disc and seat ring - stainless steel; balancing disc
	15-150 mm		D 25 bar		02 stem and disc connection nut; stem - brass, disc and seat ring - bronze
	200 mm		D 25 bar		05 stem and disc connection – nut; stem- brass, disc and seat ring – bronze; balancing disc
	15-150 mm		D 25 bar		03 stem and disc connection nut; stem, disc and seat ring - bronze
	200 mm		D 25 bar		13 stem and disc connection – nut; stem, disc and seat ring – bronze; balancing disc
	15-200 mm		D 25 bar		31 loose disc with spring; stem, disc and seat ring - stainless steel
	15-200 mm		D 25 bar		41 loose disc without spring; stem, disc and seat ring - stainless steel
	15-200 mm		D 25 bar		32 loose disc with spring; stem - brass, disc and seat ring - bronze
	15-200 mm		D 25 bar		42 loose disc without spring; stem - brass, disc and seat ring - bronze
	15-200 mm		D 25 bar		33 loose disc with spring; stem, disc and seat ring - bronze
	15-200 mm		D 25 bar		43 loose disc without spring; stem, disc and seat ring - bronze
	15-200 mm		D 25 bar		71 stem and disc connection – nut; stem, throttling disc and seat ring - stainless steel; throttling disc; without position indicator
	15-200 mm		D 25 bar		91 stem and disc connection – nut; stem, throttling disc and seat ring - stainless steel; throttling disc; with position indicator
215	E Bronze CuZn5Zn5Pb5-C	15-125 mm	C 16 bar		03 stem and disc connection nut; stem, disc and seat ring - bronze
		150-200 mm	B 10 bar		33 loose disc with spring; stem, disc and seat ring - bronze
		250-300 mm	A 6 bar		43 loose disc without spring; stem, disc and seat ring - bronze
					23 stem and disc connection – nut; with position indicator; stem, disc and seat ring - bronze
					53 loose disc with spring; with position indicator; stem, disc and seat ring - bronze
					63 loose disc without spring; with position indicator; stem, disc and seat ring - bronze
	15-125 mm		C 16 bar		73 stem and disc connection – nut; throttling disc – bronze; without position indicator
	15-125 mm		C 16 bar		93 stem and disc connection – nut; throttling disc - bronze ; with position indicator

Data given can be changed without notice.

Edition 01/2018

FIG.215

215	F Cast steel GP240GH 1.0619	15-150 mm	E 40 bar	01 stem and disc connection – nut; stem, disc and seat ring - stainless steel
		200* mm	E 40 bar	04 stem and disc connection balls; stem, throttling disc and seat ring - stainless steel
		15-150 mm	E 40 bar	11 stem and disc connection – nut; stem and disc - stainless steel; disc stellited Stellite6; seat ring - Stellite6
		15-200* mm	E 40 bar	31 loose disc with spring; stem, disc and seat ring - stainless steel
		15-200* mm	E 40 bar	71 stem and disc connection – nut; stem, disc and seat ring - stainless steel; throttling disc
215	I Cast stainless steel G-X5CrNiMo19-11-2	15-50 mm	E 40 bar	10 stop valve; seat - stainless steel
		65-100 mm	E 40 bar	12 stop valve; seat - stellite
		125-200 mm	E 40 bar	09 stop valve; balancing disc; seat - stellite
		15-50 mm	E 40 bar	40 stop check valve; seat - stainless steel
		65-200 mm	E 40 bar	39 stop check valve; seat - stellite

* DN 200, 250, 300 on request

ORDERING

Figure	Body material	Nominal diameter	Nominal pressure	Type
215	A Grey cast iron EN-GJL-250	15-50 mm	C 16 bar	00 stem and disc connection - fixed - rolled stem, disc and seat ring - stainless steel

Order example acc. index

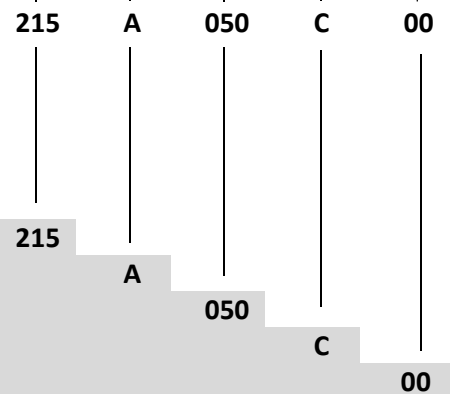

Bellow sealed stop valves, ends flanged, form straight
 Grey cast iron EN-GJL-250
 Nominal diameter (mm)
 Nominal pressure PN 16
 Stem and disc connection - fixed - rolled stem, disc and seat ring - stainless steel

Data given can be changed without notice.

Edition 01/2018