

ARCA GROUP



Reliability in Control Valves, Pumps & Cryogenics





Dynamic Expansion and Success in the Market

ARCA dates back to 1917, when Ragnar Carlstedt files his first patent for the nozzle-flapper system in Sweden. One year later, ARCA Regler AG is founded there, with Berlin to follow in 1922. In 1949, after the war, the company is refounded in Tönisvorst by Dr. Ing. Ludwig Kaspers and Adolf Paulsen and operates under the name ARCA Regler GmbH. Characterized by dynamic expansion, ARCA has no plans of slowing down in the future.

In 1970, the company expands by adding a second production facility in the Eifel region. In 1979, Dr. Ing. Rüdiger Kaspers, MBA, is appointed as the managing director of ARCA and in the 1990s, Heinz M. Nägel advances the innovative development program of the ARCA Flow Group as technical officer.

The international activities of ARCA start in the mid-1980s, when ARCA Controls Ltd. is founded in India as part of a joint venture with Forbes Marshall. In 1987, the company embarks on a successful collaborative venture with SAM YANG Valve Co. Ltd. in South Korea. In 1994, a cooperative agreement is concluded with von Rohr Armaturen AG in Switzerland and with Von Rohr ARCA BV in the Netherlands. In 1995, ARCA enters the Chinese market with its first licensee. Today, the company has its own subsidiary there.

Growth continues in the 21st century when FELUWA Pumpen GmbH joins the ARCA Flow Group in 2000. Swiss-based WEKA AG, a recognized manufacturer of cryogenic valves and level-measuring systems, follows one year later. The latest member of the ARCA Flow Group is ARTES Valve & Service GmbH in Berlin, which rounds off the product portfolio with steam desuperheaters and regulation ball valves. In 2015, the company opened its US subsidiary ARCA Flow Controls, LLC at Houston, Texas.





ARCA Worldwide!

Go to www.arca-valve.com for up-to-date information about our established representative offices and contacts.

Our joint venture partners:

- **INDIA**
www.forbesmarshall.com
- **SOUTH KOREA**
www.samyang-arca.co.kr
- **CHINA**
www.arca-valve.com.cn
- **MEXICO**
- **USA**
www.arca-valve.com

The ARCA Flow Group: A Global Corporate Group

Globally active, the ARCA Flow Group's secret to success is embracing innovations by designing them around customer requirements and advancing their underlying technology to the next level. Promoting new ways of doing things goes back to the early days of ARCA, and many innovations followed to safeguard a competitive advantage for our customers. Still a family and employee-owned enterprise, the ARCA Flow Group prides itself on being close to its customers and practically oriented as a mid-sized company.

Over 500 employees around the world contribute to realizing our corporate vision, which reads as follows:

«We pursue long-term employment with ARCA, satisfaction in our work, and collaboration with customers so that both sides can be proud of the end result.»

ARCA develops, manufactures, and markets control valves on an international scale primarily for the chemical, food, power, and oil and natural gas industries. ARCA has also become a globally active corporate group and is well represented not only in Europe, but also in Asia and America with joint ventures, subsidiaries and collaborative partners in India, South Korea, The People's Republic of China, Mexico and USA. Adding to this are representatives and sales offices that can be found in all European and many non-European countries. FELUWA Pumpen GmbH and WEKA AG in Switzerland supplement the product line-up with pumps and cryogenics.



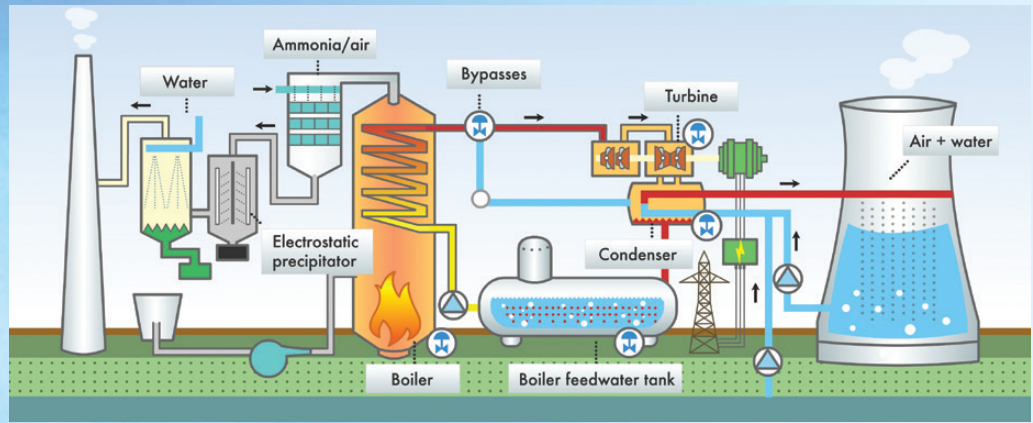

ARCA Technology as Key Components in Power Plants

High-performance control valves from ARCA are capable companions in industrial and large-scale power plants by ensuring safe and reliable operation and can be used in all high and low-pressure steam, oil, gas, water/boiler feedwater, and condensate circuits.

The steam-conditioning stations of the 500 series form the heart of a power plant by functioning as start-up, HP-MP/HP-LP, and bypass stations. They are required during start-up, operation and shut-down, for isolated operation, and can be integrated as safety shut-off valves in accordance with TRD 421 (technical guide-lines for steam conditioning) or as SIL equipment.

Our ECOTROL® valves can assume a variety of control tasks in many processes and are thus ideal for applications involving level, pressure, and temperature regulation. Different trim designs and graduated steps are designed specifically for the process in question.

The steam-conditioning valve, the basic component of a steam-conditioning station, reduces live steam pressure in multiple regulated and unregulated reduction steps, and the modular system offers several possibilities for injecting cooling water to reduce the temperature for the downstream process. The application itself and relevant constraints point to the system and design that are most appropriate, the latter of which is typically angular.

Modular construction of ARCA valves also makes it possible to exchange valve internals without having to remove the entire valve assembly.

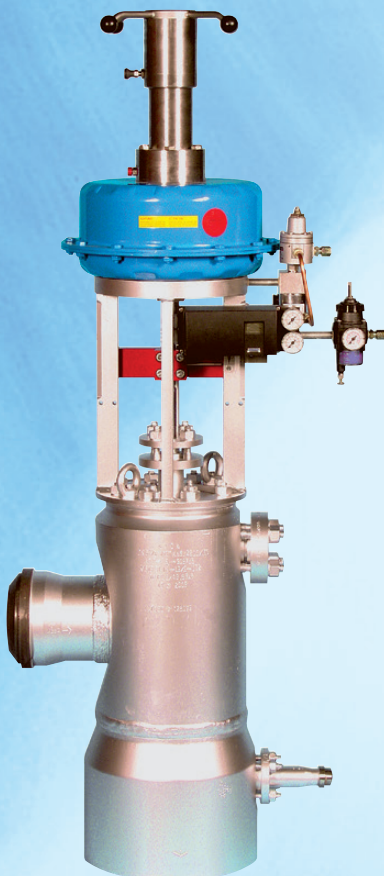

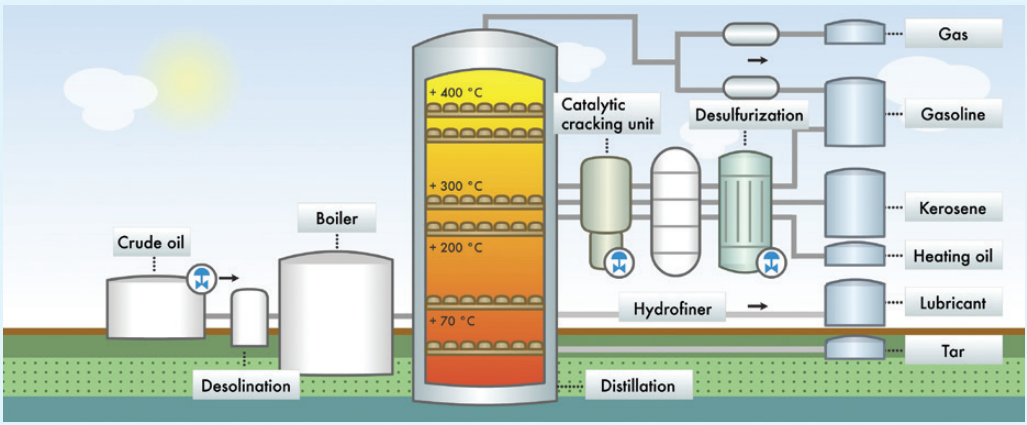

Petrochemical and Steel Industry

Oil and natural gas are the primary sources of energy driving the global economy. Extraction carried out under extreme offshore conditions and in the icy temperatures of Siberia, the desert heat of Africa and Asia, and tropical climates, combined with storage and processing in refineries, make this market the most demanding when it comes to providing control valves that perform day in and day out. ARCA valves have helped ensure production and process reliability in the oil and natural gas industries for many years, and a wide variety of precision-engineered control valves are available that include DN15 (1/2") to DN600 (24") and PN16 to PN400 (ANSI 150-2500) sizes as well as special-purpose valves for all media handled in these areas.

ARCA valves are also indispensable in steel production. To this end, ARCA has developed control concepts and combined valves with intelligent systems so that the valve selection can be adapted in exact alignment with the production process.

Steel production and processing require valves that offer ultra-high performance and a long service life. In the steel and rolling mill industry, ARCA is a leading international supplier of control valves and systems and impresses with innovative technology, economy, quality, and reliability.

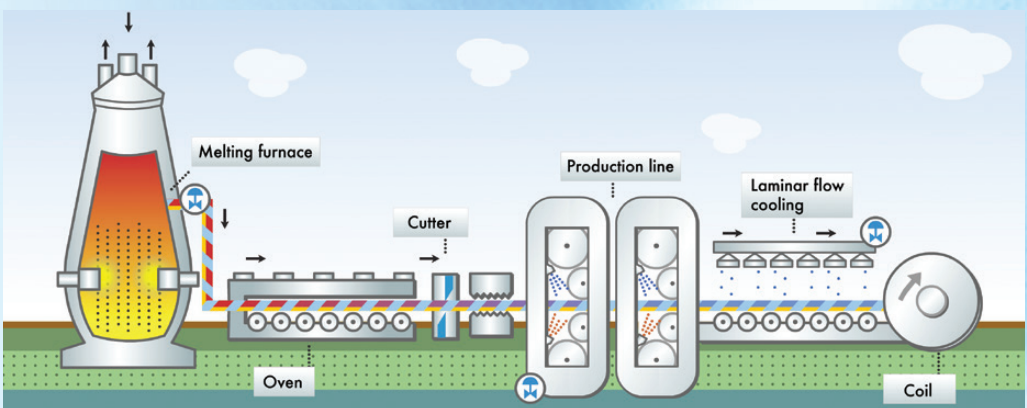

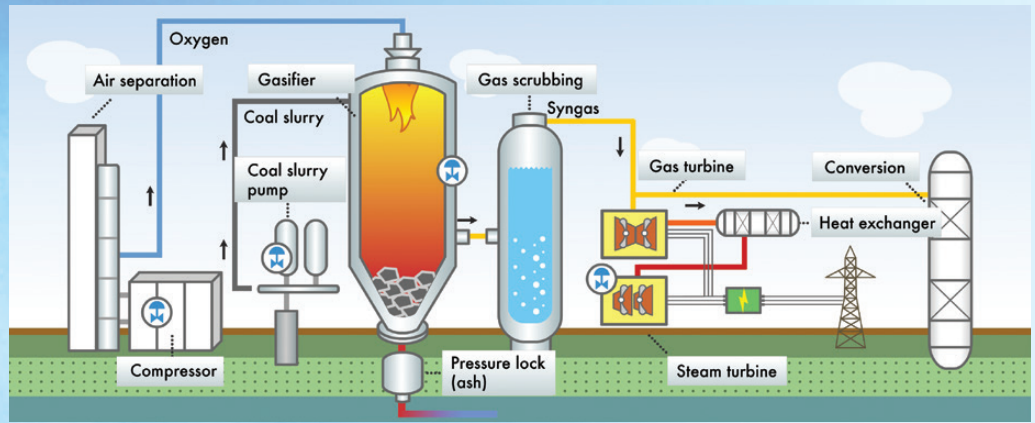

Coal Gasification Meets Tomorrow's Needs

Programs and projects for manufacturing synthetic fuels are becoming increasingly popular in view of fluctuating oil prices, the importance of securing reliable energy supplies, and the lack of coal and coke.

The ARCA Flow Group, with its expertise in developing and manufacturing control valves for abrasive media and oxygen, steam and water valves for the entire heat recovery circuit, and FELUWA hose diaphragm piston pumps, provides comprehensive solutions for all methods of coal gasification and downstream chemical processes as well as for producing energy from coal gas.



Safety and Economy: The ARCA Anti-Surge Control Valve for Compressors

Integrated in the bypass section of turbo-compressors, ARCA valves reliably carry out multiple tasks simultaneously by assisting during the start-up and shut-down phases of the compressor. Excess amounts of gas are diverted or blown off at critical points and when the machine must be kept operating at constant speed as consumption fluctuates. The most important function, however, is that of the safety valve as used to provide protection for the pump. Proven ARCA valves reliably prevent pumping action when a stall is encountered or a minimum flow rate is undershot.

ARCA also provides the control valves needed to acquire and process natural gas through to storing it in caverns.



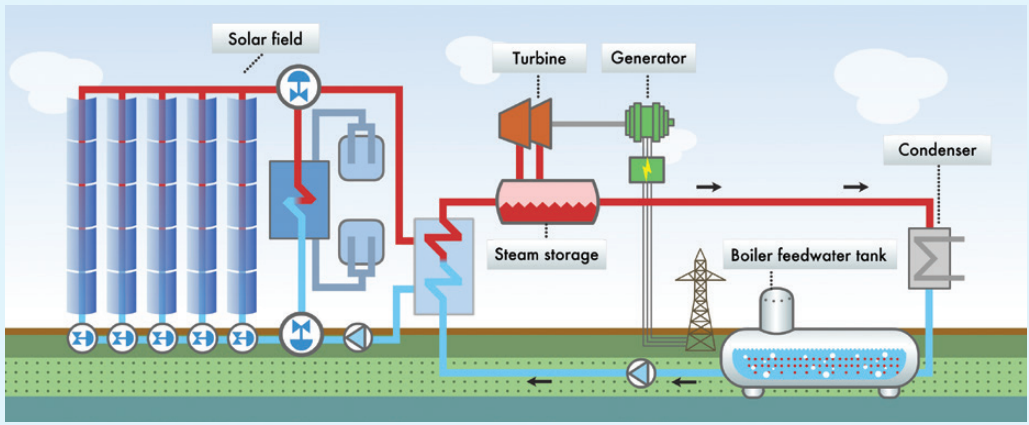

CSP Power Plants – Technology of the Future

Concentrated **Solar Power** plants convert solar radiation into electrical energy. Systems that use thermal oils as a heat-transfer medium produce temperatures that can reach 400 °C at approximately 40 bar in the solar array. Thermal oils are frequently toxic and highly flammable, however, which is why the outward-facing side of the valves fitted to these systems must be particularly well sealed. Such applications integrate reliable ECOTROL® 6H high-pressure valves, which feature a bellows seal.

Control valves are especially taxed during the start-up and shut-down procedure as they counteract the fluctuations inherent in the process or system. Since this procedure takes place once a day, the control valves must operate reliably to safeguard the availability and efficiency of the system.



Responsibility for Products, Operational Reliability, and the Environment in the Chemical and Food Industries

Products from the chemical industry can be found everywhere today and are used in many different environments. Each of these environments places special demands on the control valves used, which range from reliable outward sealing for the highly toxic intermediate products created during plasticizing, to corrosion resistance for processes involving chlorine chemistry, through to absolute sterility in the pharmaceutical and food industries. ARCA delivers by offering bellows seals that meet the strictest air quality requirements as well as a large number of highly corrosive-resistant materials. The BIOVENT® control valve developed for the food industry, for example, is available in many designs and connection layouts and with drives and positioners in stainless steel to cater to all applications.



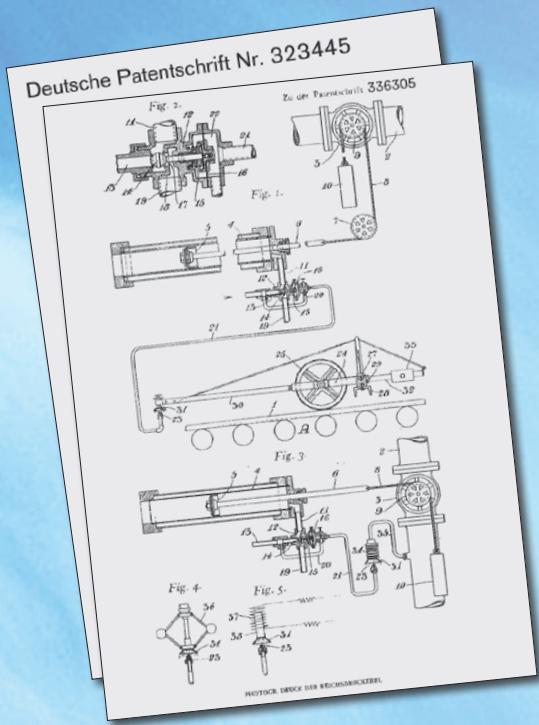

Never-Ending Search for a Better Solution

The success of the ARCA Flow Group builds on an innovation that was filed for patent protection long ago and would not have been possible if the founder were not driven to find a better solution. Today, this spirit lives on and has become an inseparable part of our history and corporate culture.

The drive to innovate is therefore just as current now as it was then. Take the ARCASMART, for example. The first actuator with a fully integrated intelligent positioner, it is ideal for challenging applications that involve strict hygienic requirements or extreme ambient conditions.

OPOS® Interface is an innovative standard interface that reliably and efficiently connects an intelligent positioner and a pneumatic actuator. Generic in design, the interface does not restrict users to specific products and was developed as part of a strong partnership between ARCA, bar, and Siemens company.

The future is full of change as well, since we plan to continue investing in research and development and leverage our daily interaction with customers to find new ways of doing things, improve existing products, and make quantum leaps in technology.



Designing with State-of-the-Art Methods

Our technicians and engineers design using state-of-the-art, networked 2D and 3D CAD workstations that simulate all processing steps while taking into account the different materials and respective tooling and machine parameters. NC programs are then written and transferred to the machine tools in the turning and milling stations.

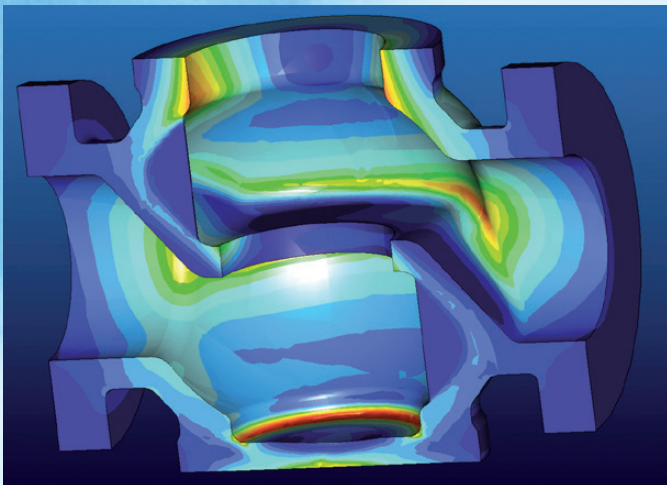

Economic Success with Optimized Processes

The ARCA Flow Group uses SAP technology to optimize its business processes, which are streamlined from the moment the customer contacts us to the day on which the product is delivered. Working closely with Quality Assurance, shop personnel manufacture the individual components for the valves to the required high level of precision so that the product can be assembled quickly and without complication. A final quality check is then carried out to ensure that the product fulfills all of the customer's requirements in terms of its features and response.

Manufacturing takes place at the main factory in Tönisvorst and in the branch factory in Vulkan Eifel, which focuses on standard parts, entire valve series through to DN 100/PN 40, and pneumatic multi-spring diaphragm actuators. Workers in Tönisvorst, on the other hand, fabricate valves up to a nominal diameter of DN 1200, high pressure valves PN 63 and above, forged and steam-conditioning valves, and all types of pneumatic actuators. Oxygen valves are also machined and assembled under cleanroom conditions in Vulkan Eifel.

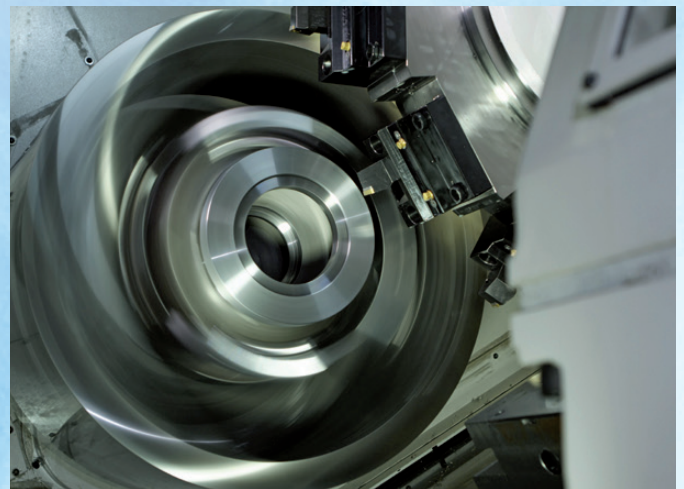



We Minimize Lifecycle Costs

We not only manufacture complex, ultra-high-performance valves, but are also the perfect partner when it comes to maintenance and repair as well as complex instrumentation. ARCA valves are exceptionally durable, and our customer support staff are happy to provide the assistance you need for ongoing care and maintenance work. An experienced team of technicians professionally services your equipment on site and can quickly respond to unforeseen situations, regardless of where you are located. This, in turn, can have a considerable impact on the service life of your valve and the operating reliability of the plant.

Inspections and conversions are carried out quickly and thoroughly by experts, and we can also accommodate valves from other manufacturers thanks to our proven ARCA know-how and decades of experience.

ARCA Quality Speaks Volumes

Certified to the ISO 9001:2008 standard, our quality management system lays the groundwork for realizing optimally designed products that are reliable and exceptionally durable. We have also achieved compliance with many national quality standards to facilitate business around the world and underscore our know-how and international reputation, and are certified to ISO 14001:2009, the international standard for environmental management systems.

All ARCA valves are subjected to ongoing quality checks that start at the planning and development stages and continue through to manufacturing and final inspection. During this time, the valves are verified for proper performance under established working conditions to ensure absolute dependability.



Our Employees Are Our Main Asset

ARCA has maintained its leading position in the global market for decades primarily because it has adopted a sustainable personnel strategy and has received the «TOP JOB» award for mid-sized companies in recognition of its exemplary HR program. The large number of patents we have filed also testifies to our commitment in furthering the skills and creativity of our employees.

«Pushing and promoting» is the guiding principle behind our personnel strategy. By establishing transparency, fairness, and an open-door policy, we foster the strengths of all individuals so that they can cater to customers' needs while meeting their own professional objectives.

We like to compare ourselves to a world-class orchestra, since a company also has to rely on teamwork to produce exceptional results. While one player is busy trumpeting, another provides the subtle tones required to carry on the background melody. In the end, both are required to bring about the desired effect. For our employees around the world, such balance translates to a corporate culture rooted in teamwork, respect, responsibility, integrity, and innovation.

Our company encourages education. In our apprentice workshop, for example, qualified trainers assist young people preparing for forward-looking careers at ARCA. The last five decades have seen us train over 200 youth, a number that far exceeds our own requirements, and it is in this spirit that we actively seek and develop employees who want to realize their full potential and explore the international opportunities we provide.

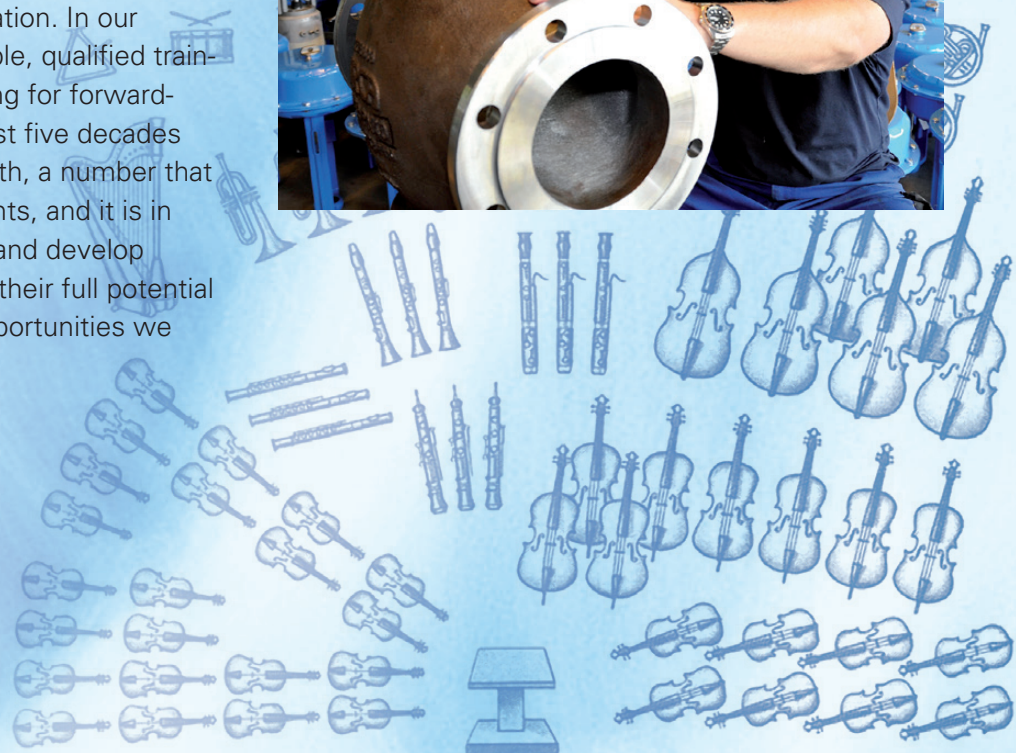
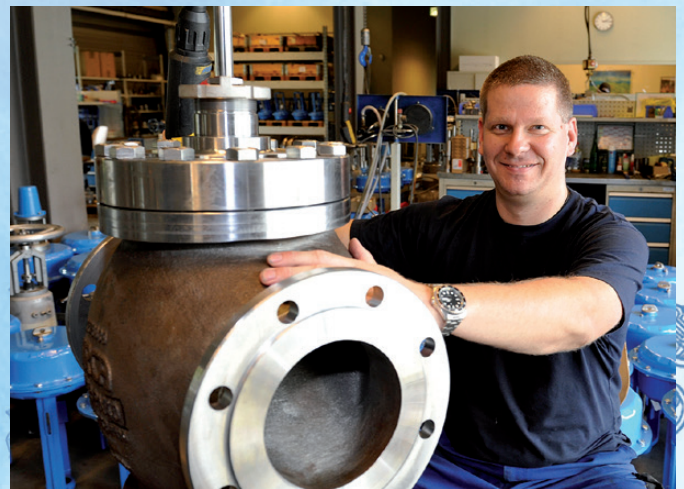
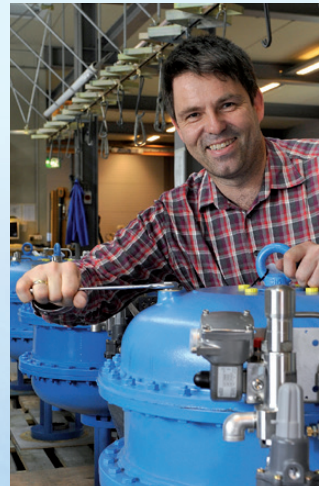

Control Valves and Valve Service

Headquartered in Berlin, ARTES specializes in manufacturing control valves for flow, pressure, and temperature controls and can service valves of all types.

ARTES valves are used in the power, natural gas, and oil industries and in various industrial plants.

Experienced employees enable ARTES to provide comprehensive engineering services, high-quality-valves and reliable valve repair services in this field.

The **ARTES product portfolio** comprises:

- Control ball valves for flowcontrol in water and steam circuits
- Control ball valves for use in flue gas desulfurization plants
- Control ball valves for flow control of natural gas, brine, and petrochemical products
- Desuperheaters and motive steam coolers for steam temperature control
- Steam conversion stations
- Primary differential pressure devices

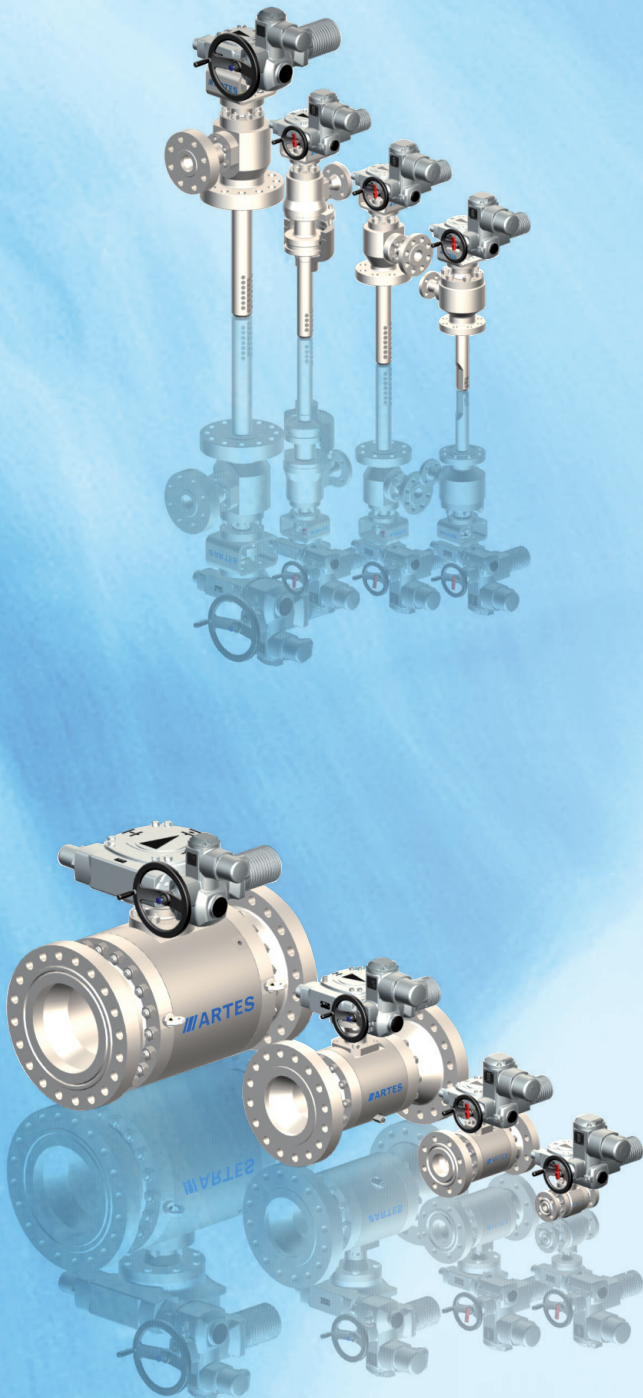



Competence in Pumps

FELUWA Pumpen GmbH is headquartered in the Vulkaneifel region and has been a member of the ARCA Flow Group since the year 2000. The company is a leading manufacturer of pumping technology and has at its base in excess of 100 years' corporate history. For 50 years plus, FELUWA has been focusing on the development, fabrication, commissioning and after-sales service of pumps for solids-carrying and other challenging products.

At the heart of FELUWA's production is its patented MULTISAFE double hose-diaphragm process pump. It is successfully applied worldwide for the handling of chemically aggressive, mechanically abrasive, fluid and highly viscous media in a great variety of fields, such as power, metallurgical, mining, chemical, petrochemical, pharmaceutical and general process engineering industries or hydrotransport applications.

For extraordinary company and product development, FELUWA has been honoured by multiple awards, such as the Premier of the Grand Prix of Medium-Sized Enterprises and the Holkenbrink Award.

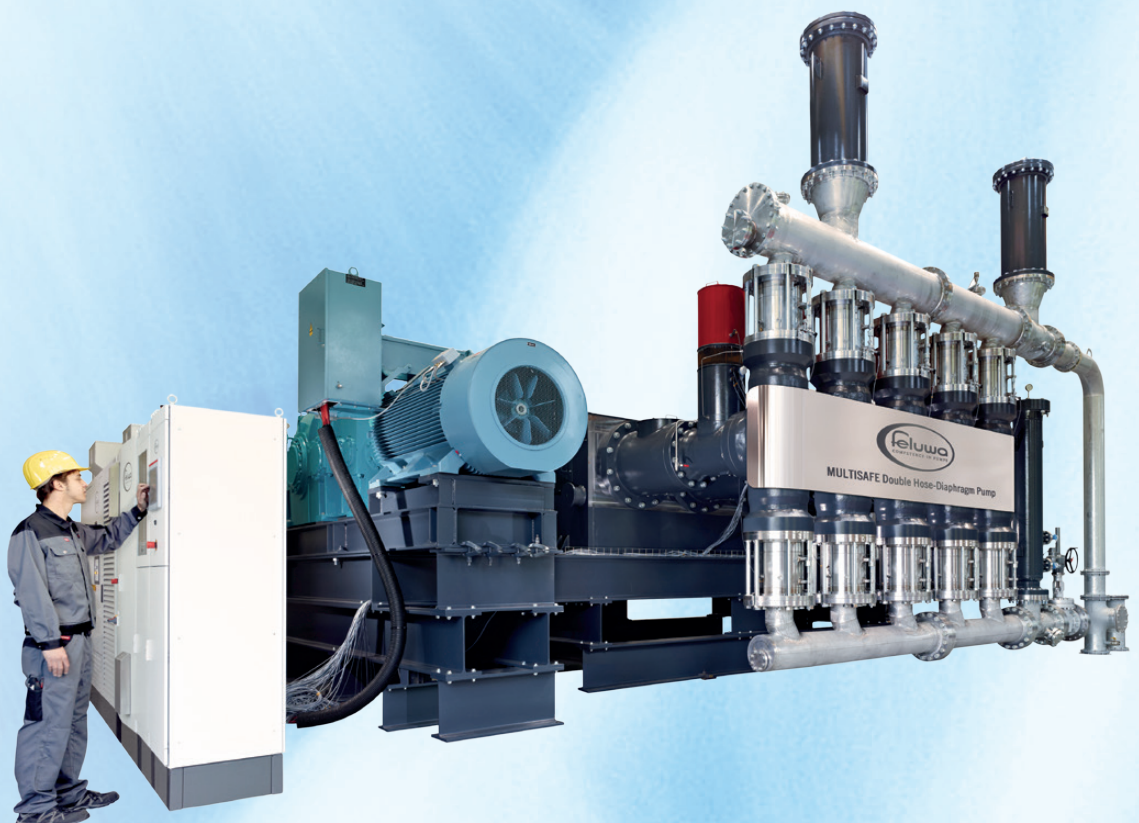



Precision by Tradition

The valve line of von Rohr Armaturen AG encompasses the entire range of cost-effective standard valves offered by the ARCA Flow Group and the Swiss tradition of combining such valves with long-term value retention continues in the 8B series. Special customer requirements are also realized in professional and innovative fashion by the qualified team of engineers and technicians.

A specialist for pneumatic and electrically-actuated valves, the «von Rohr» name has been synonymous with precision-milled, high-quality products since 1954. Von Rohr is a member of the ARCA Flow Group and is headquartered in Switzerland and the Netherlands.

Industries served:

- Chemical, biotechnology and pharmaceutical (sterile equipment) industries
- Food and beverage industry
- Petrochemical and natural gas industry
- Paper and pulp industry
- Energy industry (power plants and district heating)
- Disposal and municipal facility industry

Assembly, commissioning and aftersales services are performed by highly skilled personnel. This not only facilitates proximity to the customer, but also allows the company to resolve control tasks in minimal time and leverage the knowledge gained to develop valves with even higher levels of performance.





Innovation in Liquid Level Measuring and Valve Technology

Swiss-based WEKA AG is a member of the ARCA Flow Group since 2001 and offers a wide range of level-measuring instruments, cryogenic components and highly specialised valves. Quick and flexible response to customer requests is a key asset of this medium sized company. WEKA specialises in the development, production and testing of custom made solutions in level measurement using the magnetic float principle. Cutting edge technologies are used for highly specialised valves and other components in the cryogenic field and other extreme operating conditions. The WEKA brand stands for highest quality products worldwide.

Well over 90 percent of WEKA's turnover is generated from the international market. Level instruments are generally distributed over a global network where as the cryogenic components are usually handled directly. WEKA is internationally perfectly placed and one of the market leaders in cryogenic process technologies.

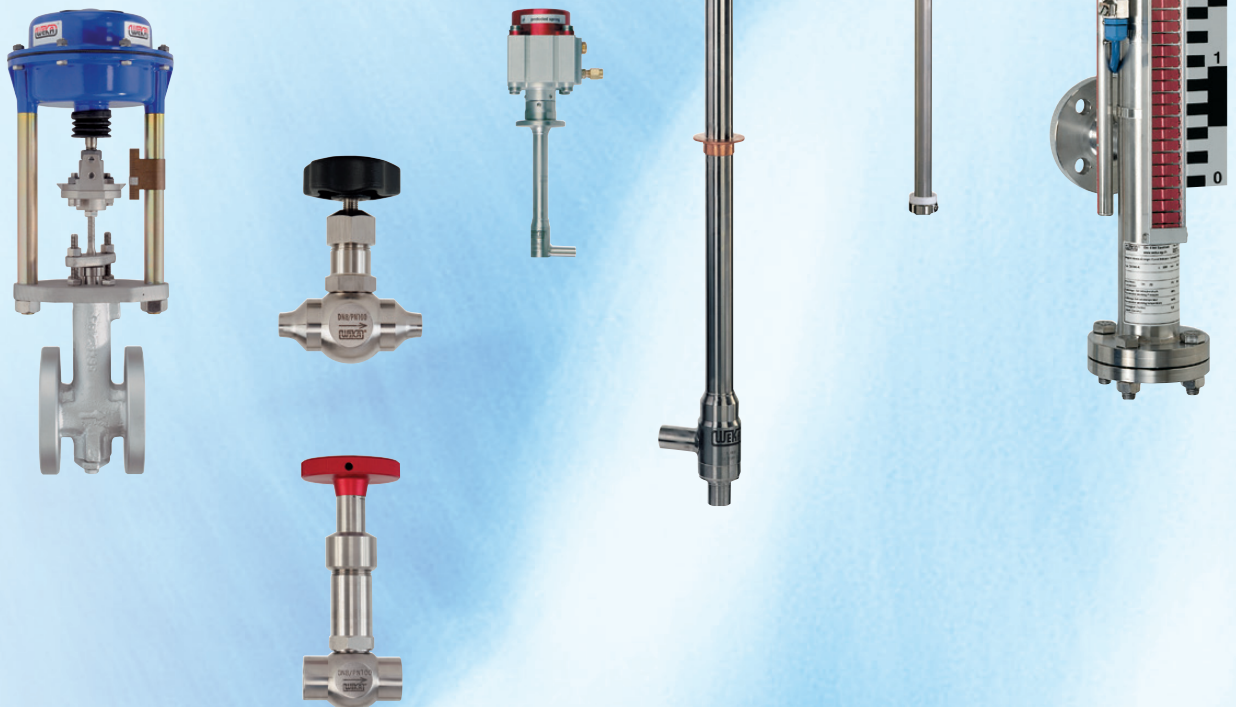

ARCA GROUP



A range of awards confirms our professional approach to business
and motivates us to continue aspiring to new heights!

Visit the following Web sites for up-to-date information about our
global network of representative offices and contacts and to learn about
innovations and current trade show appearances:

www.arca-valve.com

You may contact our Singapore Partner:



MV Resources (FE) Pte Ltd
31 Benoi Road (Pioneer Lot),
Singapore 627778
Attention: Mr Sean Lim
Mobile: +65 91198320
Email: sean@mvmfareast.com.sg

Quality made by ARCA Flow Group

ARCA Regler GmbH, Kempener Str. 18, D-47918 Tönisvorst
Phone +49 (0)2156-7709-0, Fax +49 (0)2156 7709-55, sale@arca-valve.com